

SMD Inductors(Coils) For Power Line(Multilayer, Magnetic Shielded)

Conformity to RoHS Directive

MLZ Series MLZ1608

This is a multilayered inductor primarily designed for choking power lines. With one of the best resistance performance in the industry, this product delivers a significantly lower DC resistance value compared to our previous products. This reduces the loss at the power supply and contributes to power conservation.

FEATURES

- IDC-UP goods (1.0 to 10.0 μ H) and low inductance goods (0.1 to 0.47 μ H) have been newly added.
- Significantly reduced Rdc.
- An inductance value of 0.1 to 10.0 μ H was realized using the 1608 form. This contributes to space saving.
- Automatic mounting in tape and reel package.
- The products contain no lead and also support lead-free soldering.
- It is a product conforming to RoHS directive.

APPLICATIONS

Choke coil to use for DVC, DSC, MD, power supply circuit such as various module.

SPECIFICATIONS

Operating temperature range	-55 to +125°C
Storage temperature range	-55 to +125°C

RECOMMENDED SOLDERING CONDITION REFLOW SOLDERING

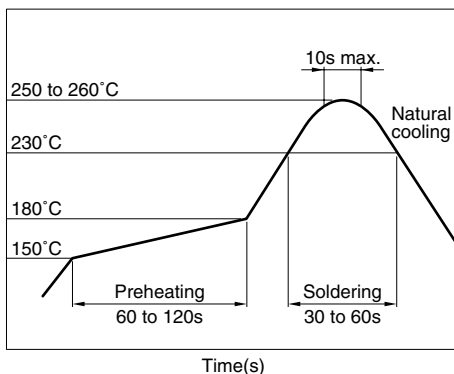

PRODUCT IDENTIFICATION

MLZ	1608	A	1R0	M	T
(1)	(2)	(3)	(4)	(5)	(6)

(1) Series name

(2) Dimensions L×W

1608	1.6×0.8mm
------	-----------

(3) Material code

(4) Inductance value

R10	0.1 μ H
1R0	1.0 μ H
100	10.0 μ H

(5) Management symbol

M	STD
W	IDC-UP

(6) Packaging style

T	Taping [reel]
---	---------------

PACKAGING STYLE AND QUANTITIES

Packaging style	Quantity
Taping	4000 pieces/reel

HANDLING AND PRECAUTIONS

- Before soldering, be sure to preheat components. The preheating temperature should be set so that the temperature difference between the solder temperature and product temperature does not exceed 150°C.
- After mounting components onto the printed circuit board, do not apply stress through board bending or mishandling.
- The inductance value may change due to magnetic saturation if the current exceeds the rated maximum.
- Do not expose the inductors to stray magnetic fields.
- Avoid static electricity discharge during handling.
- When hand soldering, apply the soldering iron to the printed circuit board only. Temperature of the iron tip should not exceed 350°C. Soldering time should not exceed 3 seconds.

• Conformity to RoHS Directive: This means that, in conformity with EU Directive 2002/95/EC, lead, cadmium, mercury, hexavalent chromium, and specific bromine-based flame retardants, PBB and PBDE, have not been used, except for exempted applications.

• Please contact our Sales office when your application are considered the following:
The device's failure or malfunction may directly endanger human life (e.g. application for automobile/aircraft/medical/nuclear power devices, etc.)

• All specifications are subject to change without notice.

SHAPES AND DIMENSIONS/RECOMMENDED PC BOARD PATTERN

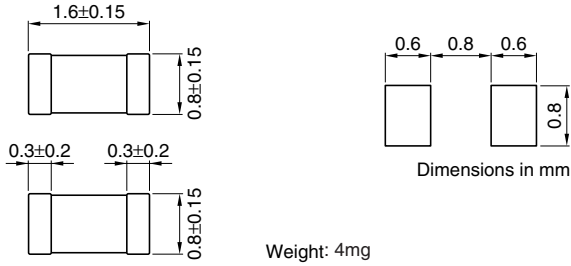

ELECTRICAL CHARACTERISTICS

Part No.	Inductance (μH)	Inductance tolerance	Test frequency L (MHz)	Test current L (mA)	Self-resonant frequency (MHz)typ.	DC resistance (Ω)±30%	Rated current (mA)
MLZ1608DR10MT	0.10	±20%	25	1.0	600	0.14	700
MLZ1608DR22MT	0.22	±20%	25	1.0	400	0.27	550
MLZ1608DR47MT	0.47	±20%	25	1.0	260	0.42	400
MLZ1608A1R0MT	1.0	±20%	10	1.0	170	0.17	150
MLZ1608A2R2MT	2.2	±20%	10	1.0	120	0.30	100
MLZ1608E4R7MT	4.7	±20%	2	0.1	70	0.50	60
MLZ1608E100MT	10.0	±20%	2	0.1	50	0.90	40
MLZ1608A1R0WT	1.0	±20%	10	1.0	170	0.15	190
MLZ1608A2R2WT	2.2	±20%	10	1.0	120	0.25	130
MLZ1608M4R7WT	4.7	±20%	2	0.1	70	0.50	120
MLZ1608M100WT	10.0	±20%	2	0.1	50	1.05	90

- Test equipment
Inductance: Ag-4294A+16034G

TYPICAL ELECTRICAL CHARACTERISTICS

INDUCTANCE vs. FREQUENCY CHARACTERISTICS

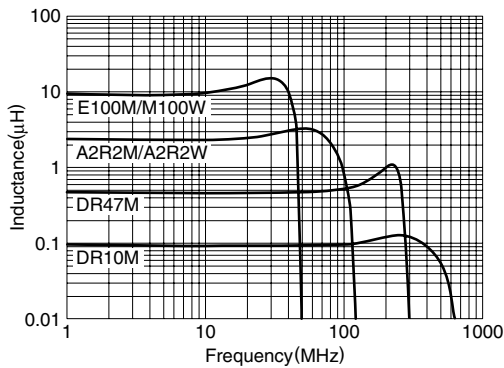

IMPEDANCE vs. FREQUENCY CHARACTERISTICS

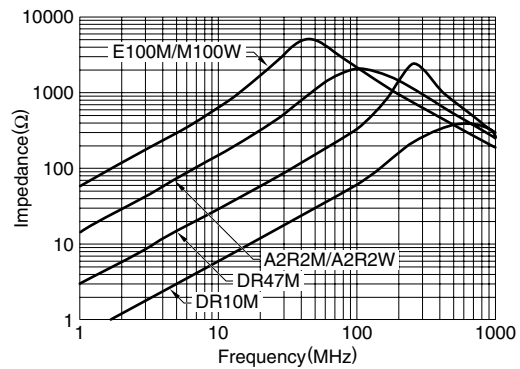

INDUCTANCE CHANGE vs. DC SUPERPOSITION CHARACTERISTICS

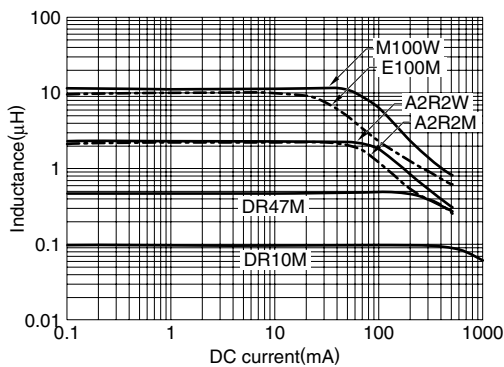

TEMPERATURE CHARACTERISTICS

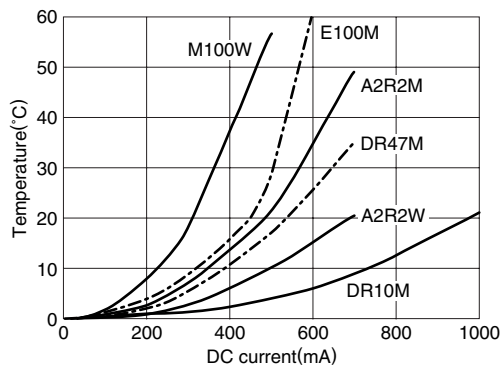

• All specifications are subject to change without notice.

PACKAGING STYLES
REEL DIMENSIONS

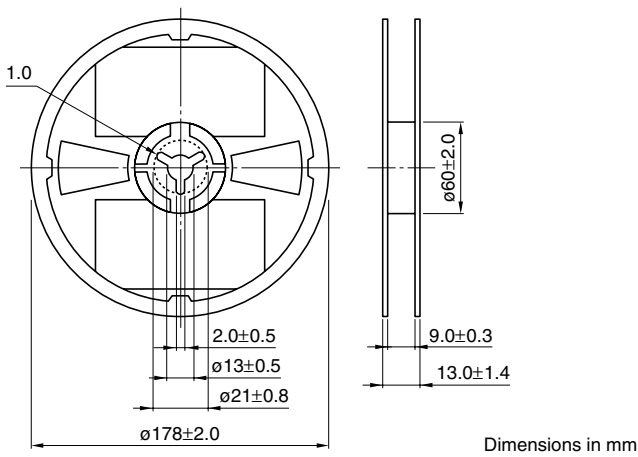

TAPE DIMENSIONS

